

An Energy-Efficient Clustering with Hybrid Coverage Mechanism (EEC-HC) in Wireless Sensor Network for Precision Agriculture

Pratishtha Parganiha* and Kakelli Anil Kumar

School of Computer Science and Engineering, Vellore Institute of Technology, Vellore, Tamil Nadu, 632014, India.

Received 12 March 2018; Accepted 18 July 2018

Abstract

Energy conservation and network throughput are the important performance metrics for wireless sensor network applications because the network may prefer to deploy in an unattended and unmanned geographical environment. The wireless sensor nodes are having irreplaceable and limited power source hence the performance of WSN is purely depends on lifetime of each sensor node. The node energy exhaust happens quick when continuous sensing, processing, storing, and communication of the parameters of targeted environment. Cluster topology is an important technique proposed to achieve energy conservation and better network lifetime. The existing clustering techniques are not capable to achieve higher throughput and desired network lifetime due to un-coverage area in sensor field. Hence, we proposed a new energy efficient clustering with hybrid coverage mechanism (EEC-HC) to achieve energy efficiency, better coverage and high throughput. The proposed EEC-HC has estimated the minimum clustering cost function and optimum number of sensor nodes using optimum distance to minimize the un-coverage area in sensor field. The EEC-HC mechanism has given a better solution for detection of animal intrusions in agriculture fields and provided smart fencing.

Keywords: Wireless Sensor Node (WSN), Clustering, Residual energy, Hexagon, K-connectivity, k-coverage, Smart fencing, Animal Intrusion.

1. Introduction

Wireless sensor network (WSN) plays a key role in all emerging fields like agriculture, military, environmental, industrial and research. A wireless sensor network is a wireless network consists of self-directed devices and use variable types of sensor nodes to sense, process, store and communicate the physical condition like temperature, pressure, humidity, pollutant like CO₂, CO, methane, image and video etc. A sensor is a device sense the data and may convert into the measurable data for human use. A wireless sensor node is an integrated set of transmitter, receiver, battery and radio units [6]. It can gather sensory data, process and transmit to base station through other sensor nodes in a network. A wireless sensor node comprises a large number and small sensor nodes which works under the limited energy. Energy consumption is mainly depending upon the applications demand and set of operations performed by each node. Currently, WSN (Wireless Sensor Network) is highly demanding technology due to its emerging standard services in commercial and industrial applications. The rapid development in technical aspects of sensor node like high capable processors, communication devices, and low-power usage [3] resulting its high demand. WSN is formed by number of sensor nodes used to observe the surroundings parameters like temperature, humidity, pressure, position, vibration, sound etc. These nodes can be used in various real-time applications to perform various tasks like intrusion/target detecting, multihop communications, route discovery, data processing and

storage, monitor and control, synchronization, localization, and data transmission between source nodes to base station. The gateway node in WSN provides wireless connectivity between base station and sensor nodes as shown in figure 1.

Each node may sense/ collect the data and send to the respective cluster head node (CH), and CH node may forward the data from each sensor node to base station. Cluster node can collect, process, filter and compress to find the repeated data and transfer quality data to base station. Clustering technique may reduce energy consumption, cost of data transfer as well as memory requirement in relay nodes and base station [2]. WSN may play vital role in future internet of things (IOT), internet physical systems. WSN technology is thrilling with infinite potential for many application areas like medical, environmental, transportation, military, entertainment, homeland defense, crisis management, agriculture and also smart spaces.

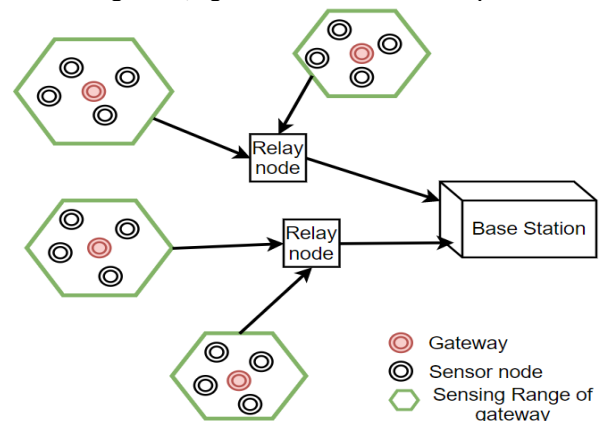

Fig. 1. Clustering in Wireless Sensor Network

*E-mail address: parganihapratishtha@gmail.com

ISSN: 1791-2377 © 2018 Eastern Macedonia and Thrace Institute of Technology. All rights reserved.

doi:10.25103/jestr.113.13

In these applications, many sensor nodes are deployed either in deterministic manner or in random way to perform an allocated wireless operation. Due to the energy conservation is crucial to increase life time of the node. Therefore, it is a challenge to develop the healthy and energy effective WSN application.

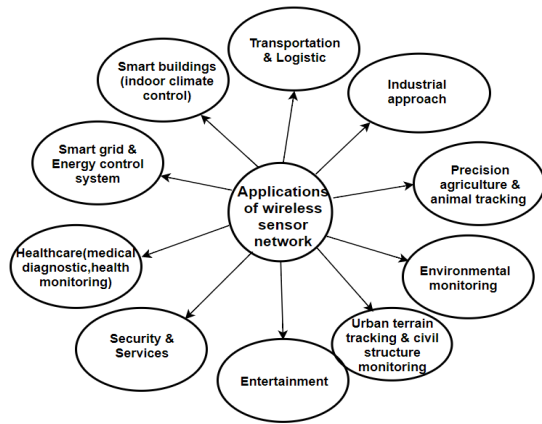

Fig. 2. Wireless Sensor Networks Applications

1.1 Motivation

Precision agriculture is main focus in all agriculture application because it helps users to maintain their farms or fields in a better way as compared to the old days. In agriculture fields, the most frequent problems like in poor water management [11], low soil moisture [5], animal attacks [4]. WSN can be the best technology to solve these problems in terms of placing sensor nodes in targeted area to manage the water supply or soil moisture retention using intelligent water pump control with help of GSM. Another important and most frequent problem is animal intrusion attacks in agriculture fields. Now a day’s animal attack in agricultural fields is resulting death of many farmers and loss of quality agriculture products. Hence it is highly essential to develop a smart fencing system to overcome the problems like detection and avoid the animal/ enemy intrusions in targeted/sensitive areas. WSN with clustering technique is a best choice for energy efficient data transmission with low cost in better way. To save the energy consumption of an optimum number of cluster node are present in the cluster network when the data is communicated between cluster head to base station. Automated systems are part of the agricultural processes leading to high yield and maintaining good quality of the crop. These systems are easily available and adaptable by the farmers. The focus of the proposed system is to create closed loop animal intrusion detecting system, which is applicable of sensing, reporting and taking preliminary action in an automated manner. To make the system more cost effective, a set of sensors and related gadgets are identified and used in wireless sensor network development process. The foremost concern of this paper contribution is the application of WSN and use technology assisted upgrades to achieve crop protection without hurting animals and diverting them in appropriate way.

Problem Statement

1. Based on the literature survey, the existing work has not clearly specified about the deployment of sensor nodes in sensing field.
2. K-connectivity and K-coverage is one of the important techniques for deployment of sensors however these

techniques are result still uncovered area in sensor field. Uncovered area results limited throughput and low-quality routing path for data transmission.

3. Using of electric fencing in agriculture fields is dangerous for animals and farmers as well. To resolve these problems, the prosed are designing a model in which sensors are placing in the boundary of the agriculture area in hexagonal shape.

Deployment, Coverage and Clustering in WSN:

Energy consumption in network is one of the major and main factors in Clustering because 90% energy of the nodes is used for data transmission only. Cluster node is the nodes to send the data to base station through minimum usage of energy and also minimize the data transmission cost. There are many possible deployments for clustering like circle, square, rhombus, hexagon, triangle and etc. Among all these, circular is one of the most common methods used for clustering but the disadvantage is it may not achieve 100% coverage of sensor field. However, the other deployments like triangle, square, hexagon are providing better coverage with minimum uncovered area in sensor fiends. The below table 1 shows the coverage and un-coverage area of sensing area.

Table 1. Comparison of coverage and un-coverage areas of various deployments

Shape of Sensing Area	Sensing Area	For 1 Sensor	Total Coverage Area	Non-Sensing Area
Triangle	100	57.7	99.9364	0.0636
Circle	100	7.954	99.9897	0.0103
Hexagon	100	9.622	99.9918	0.0082

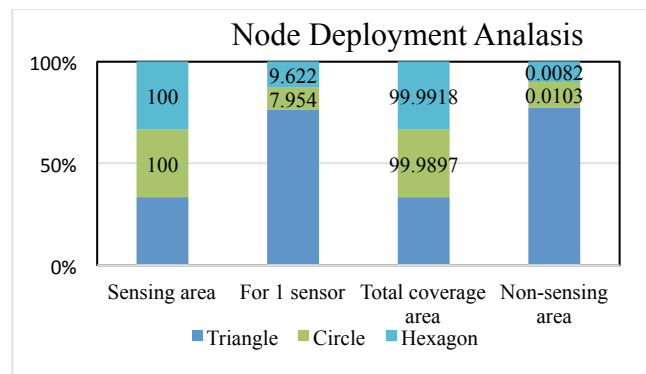

Fig. 3. Comparative study of WSN topologies

1.2 Contribution

In our proposed work, the following analytical data may useful for further analysis.

1. An analytical expression is developed for finding a residual energy, distance between base station and gateway, the cost of cluster head for sending and receiving data to base station and receive from sensor node respectively.
2. The impact of data accumulation ratio on the energy consumption of the concerned network is analyzed by an equation (4.1).
3. To find out the approximate distance between the sensor node and base station is explained in an equation (4.6).
4. For finding the total cost of the cluster head node for transmitting and receiving the data is explained in one equation (4.9).

2. Literature Survey

The main focus of work is sensor node coverage, and communication through clustering multihop for agriculture applications [1]. A cloud technology collects the data from WSN applications like application of soil moisture, protecting crop from pests and from animals attack and can stores in cloud. It means WSN and cloud are forming a frame work called sensor cloud virtualization which helps the users to get the information about the agriculture field regularly. In sensor cloud, users can give input as request and get data from cloud as response. Continues sensed data is stored in sensor cloud virtualization from base station [3]. A Zigbee technology [2] for high level communication is used to create personal area network with low power, digital radio and low rate of data. It is wireless technology developed as an open global standard to address unique need of low cost, low power wireless M2M network. Grid topology used to collect the data from the sensor nodes, each set of nodes called a sensor node, which is sending a data locally to the base station from the different areas that makes a global decision about the physical environment of the agriculture area [2]. To uses a micro controller and ZigBee technology for getting a soil moisture, and in which duty scheduling process is using to take the reading from the soil that also helps to save the power consumption because each sensor is working in a time interval of 30 minutes. After each 30-min sensor is taking reading from the soil and remaining time reach to an idle state [7]. A technique called W-COHOG which gives accurate result as compared to the three existing techniques HOG, COHOG, R-COHOG [10]. There are two types of data sets first is camera trap which is captured by camera and other set is old data set which is the old pictures of wild animals. Taking pictures of animal from fields and matching it with the old image, to recognize that which animal is attacking the field [10].

An application protects the agriculture field from an animal attack. The proposed WSN application diverts the animal through noise alarm device if any sensor senses the presence of animal near the field. The sensor nodes are placed in the four corners of sensor field and each node passes the laser assist perimeter guarding sensor to detect the presence of animal. If any animal is near to the field, it sends the message to base station or central station, and central station detects the sensor is near to the animal and start alarming to diverting the animal. It sends image message to the user also to notify the presence of animal near the field [4].

For calibrating soil moisture from soil moisture sensor, the deployment of sensors is at 42 locations in multiple of 5 depths. 210 sensors are deployed in a CAF (cook agronomy farm) field. In first step, calculating the density of the soil moisture by the sensor and next step is to compare the results with available result, whether the sensors may give the same result or new result for the scenario. After performing these two-steps, it may conclude that the sensor needs to replace after certain period of time [5]. RF module technique is used to communicate and collect the data from sensor node for transmit the base station or central node. The central node stores the data, analyze, and send to notify the mobile client application. RF modules works on radio frequency technique which takes less data transfer cost [6]. The survey is done to analyze the behavior of the wild boar in Italy based on irregular shapes of farm. It is very difficult to protect the farms through barricade's and results high crop damage. In Italy wild boar had destroyed more number of

crops [8]. Gauri Shankar Conservation Area is located in Nepal with field size of 2179 km² area. In whole area, farmers are not cultivating due to heavy forest animal attacks, hence the research has been focused more to overcome the problem through WSN. Some parameters have taken in to the consideration like type of area, crop, animal and time of attacks to analyze. Finally, the outcome of research analysis is a monkey damaged the crops regularly and 213 legal cases have registered as compared to the other animal attacks [9, 10].

3. Network Model and Terminologies

Assumptions:

In this work, the following assumptions are considered:

1. A field of square shape preferred to modeled WSN. WSN has various types of nodes like sensor nodes, gateway, base station and CHs.
2. All the sensor nodes and relay nodes are identical and stationary after deployment.
3. Two-way connection and transmission of data in symmetric mode using equal amount of energy consumption for transmission and receive.
4. Continues sensing, data sending and receiving by nodes and relay nodes towards base station.
5. Each node can estimate the approximate distance from base station based on the receiving signal strength (RSS).
6. Base station is always placed at the center of the sensor field.

All the sensor nodes and gateway are placed manually in a preferred sensor field. Sensor nodes are connected to a gateway node if it is available in the communication range of sensor node. Generally the gateway node communication is higher than normal sensor in proposed WSN model and gateway node is well connected with base station. Connection may establish between the sensor node and gateway, if both nodes are in their communication range for efficient data transmission through strong wireless link. The strong wireless link has established from nodes to gateways and gateway nodes to base station for quality data transmission and receive in the proposed WSN model.

Depending on the communication range, connectivity, distance between nodes and gateway availability, the connection has established [13, 14]. A node can communicate the approximate distance to another node based on RSS [11, 12]. The proposed algorithm given below is used for detection of quality neighbor node based on less distance and better power source towards the gateway node:

Table 2. Algorithm for detection of quality neighbor node

1. A set of nodes is $S = \{s_1, s_2, \dots, s_n\}$
A set of gateways are $G = \{g_1, g_2, \dots, g_n\}$
2. The distance between the two nodes
 $Dist(s_1, s_2)$ or $Dist(s_a, s_b)$
3. Assume initial node energy is 2 joules, the remaining energy is represented as residual energy $E_{residual}(s_1)$ or $E_{residual}(s_a)$
4. Communication range of CH is set of gateways belongs to R_s of node s_a .
 $R_cCH(s_a) = \{g_j \mid Dist(s_a, g_j) \leq R_s \wedge g_j \in G\}$
 $R_cCH(s_1) = \{g_1, g_3, g_4, g_6, g_7\}$

Node s_1 is belongs to communication range of g_1, g_3, g_4, g_6, g_7 gateways.

5. A relay node is placed inside of field as $T = \{t_1, t_2, \dots, t_n\}$
6. $Neighbor(s_a) = \{s_b \mid Dist(s_a, s_b) \leq R_s \wedge s_b \in \{S - s_a\}\}$

Neighbor Sensor nodes s_b is the set of sensor node belongs to the communication range of node s_a .

Definition 1 (Clustering): Clustering is the process of collecting a set of sensor nodes in such a way that all node work uniformly with cluster head. The network consists of several nodes and each cluster is managed by separate cluster head of nodes. Cluster nodes may collect and filter the data before transmission to base station. The member nodes of a cluster have similar resources and capabilities.

Definition 2 (Covered Sensor Nodes 'g_a'): Covered sensor nodes is a set of all nodes in the range 'g_a' gateway (minimum 1 gateway) and the range of 'd_{max}'.
 $CoveredSensorNode(g_a) = \{s_a \in S \mid Dist(s_a, g_a) \leq d_{max}\}$

Definition 3 (Uncovered nodes and Uncovered node of set): Uncovered nodes are not having the gateway and these nodes are not in communication range of any gateway of WSN. A sensor node s_a belong to set of uncovered nodes follow the below condition as
 $s_a \in uncovered\ node\ set \Leftrightarrow [s_a \notin covered\ node\ set]$

Definition 4 (Independent, Dependent and Inactive sensor node): Independent sensor nodes are the node have their own residual energy to send the sensed data directly to base station without gateway. Dependent nodes are the node which comes under the set of clusters and these nodes need the gateway to send the data towards base station. Inactive sensor node sensor nodes are the nodes which sense data unable to send the data due to lack of connectivity with the base station.

Definition 5 (Relay Node): Relay node is used to transmit the data from one node to another. The sensing area of relay node is double than normal sensor node.

Example: Suppose a series of sensor nodes with the distance of 'r in meter' deployed. If a sensor failed due to energy exhaust, it is unable to detect the intruder object/animal may enter through its communication area. Hence it is assumed that 10 sensor nodes are deployed in a range of r. Assume if 5th sensor node may have failed due to battery failure the area of respective node has to be covered by its neighbour node/nodes. To overcome the failure of 5th sensor node and its uncovered area, the proposed algorithm has implemented n-connectivity and n-coverage system.

4. Proposed WSN Model

- a) Size of the agriculture field is $A \times A$.
- b) Deploy the nodes in the boundary of the agriculture field with distance $2r$ from edge.
- c) The field is divided into grids and each grid size is n meters.
- d) The boundary with $2r$ distance from the edge is designed in a hexagonal shape with radius r.
- e) Each node is placed with the difference of r length.
- f) The sensing range of the node is r radius.

- g) Initially nodes are in sleep mode until the intrusion enters in sensor field through duty scheduling process.
- h) Base station is placed at center of the field and transmitting nodes are randomly placed inside the field.

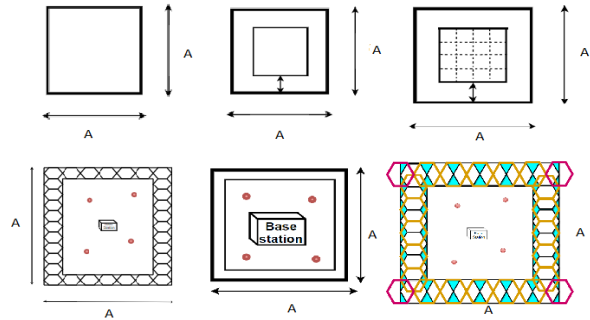

Fig. 4. WSN model with various sensor nodes

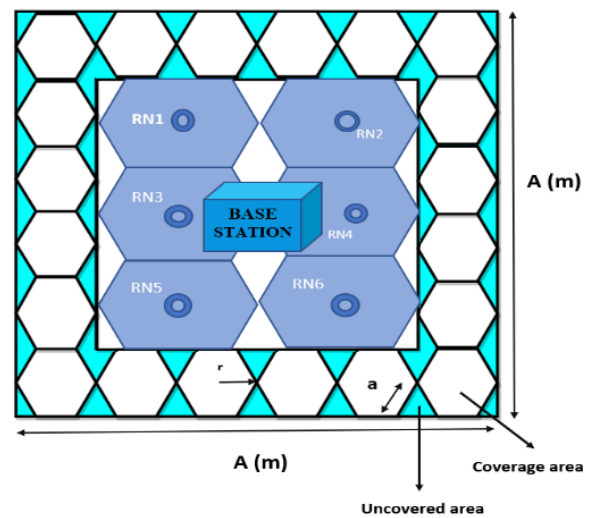

Fig. 5. Proposed WSN model with Base Station and RNS

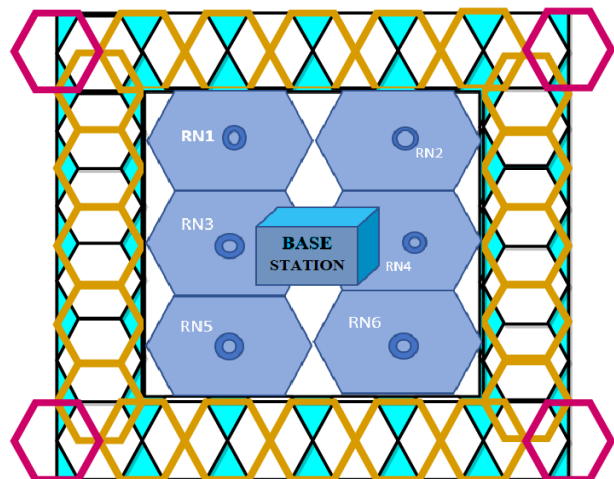

Fig. 6. WSN topology with 2-way Connectivity

At the initial stage sensor nodes, gateways, and relay nodes are undergo in bootstrapping process. Base station assigns a unique ID to each node in WSN by broadcast REQUEST message to gateway. Each gateway computes the approximate distance towards the base station using receiving signal strength. It helps the gateway to establish

the connection between the base station and gateway. After receiving REQUEST message from the base station, each gateway has to response through a REPLY message to base station. Afterwards connection has established between both nodes. Thereafter establish a network with the help of proposed clustering algorithm. The gateway receives the sense data from the cluster member and filter before transferring to the base station. The gateway broadcast REQUEST message with in the communication range of sensor nodes. The REQUEST message contains the gateway ID, residual energy level and distance to base station. Over a certain period of time, the sensor has to response to gateway by REPLY message. If a sensor node s_a receives REQUEST message from the gateway, it will become a member of a set of clustering head of respective gateway [15, 16].

[1]For residual energy of CH: Sensor node has to join the highest energy cluster head with its cluster range.

$$CH_{cost}(g_a, s_a) \propto E_{residual}(g_a) \quad (1)$$

[2]Distance between sensor node and CH:

The non-CH node consumes more energy to communication and sensor node should join the nearest CH, but energy of the CH is should be high.

$$CH_{cost}(g_a, s_a) \propto \frac{1}{Dist(s_a, g_a)} \quad (2)$$

[3]Distance between cluster head and base station:

According to the proposed algorithm, calculate the distance from gateway to relay node, thereafter from relay node to base station. Gateway is capable of sending the data up to long distance communication as compared to the sensor node. It can send the data directly to the base station without relay node, whereas in proposed algorithm, the deployed relay node may work as intermediate node between gateways and base station to transfer the data. Thus, the gateway is far away from the base station, hence it may consume more energy for communication towards the base station. Hence relay nodes may help to reduce the energy consumption at both sides of sensor node and the gateways for data transmission.

Sensor node → *Relay node* → *Base station*

For relay node (RN)

$$CH_{cost}(g_a, s_a) \propto \frac{1}{Dist(g_a, RN)} \quad (3)$$

For BS

$$CH_{cost}(g_a, s_a) \propto \frac{1}{Dist(RN, BS)} \quad (4)$$

after combining equation 4.3 & 4.4

$$CH_{cost}(g_a, s_a) \propto \frac{1}{Dist(g_a, RN) \times Dist(RN, BS)} \quad (5)$$

$$CH_{cost}(g_a, s_a) \propto \frac{1}{Dist(g_a, BS)} \quad (6)$$

Equation 4.1, 4.2 & 4.6 will result new equation

$$CH_{cost}(g_a, s_a) \propto \frac{E_{residual}(g_a)}{Dist(s_a, g_a) \times Dist(g_a, BS)} \quad (6a)$$

the values from equation 3 & 4

$$CH_{cost}(g_a, s_a) \propto \frac{E_{residual}(g_a)}{Dist(s_a, g_a) \times Dist(g_a, RN) \times Dist(RN, BS)} \quad (7)$$

Consider constant K in equation 4.7

$$CH_{cost}(g_a, s_a) = K \times \frac{E_{residual}(g_a)}{Dist(s_a, g_a) \times Dist(g_a, RN) \times Dist(RN, BS)} \quad (8)$$

Where K is a proportionality constant and K =1 and it does not affect the above equation,

$$CH_{cost}(g_a, s_a) = \frac{E_{residual}(g_a)}{Dist(s_a, g_a) \times Dist(g_a, RN) \times Dist(RN, BS)} \quad (9)$$

Table 3. Algorithm for Clustering Nodes

<p>Step 1: - $RcCH(s_a) = \{\}$;</p> <p>Step 2: - while (s_a receives REQUEST message from g_a)</p> <p style="padding-left: 20px;">2.1 s_a became the element of the set of clustering head node (g_a)</p> <p style="padding-left: 20px;">2.2 $RcCH(s_a) = RcCH(s_a) \cup g_a$</p> <p style="padding-left: 20px;">end while</p> <p>Step 3: - if (timeout && no REQUEST message receives)</p> <p style="padding-left: 20px;">then</p> <p style="padding-left: 40px;">s_a is not the member or element of any set of clustering head node.</p> <p style="padding-left: 20px;">end if</p> <p>Step 4: - if ($s_a \notin$ set of clustering head node)</p> <p style="padding-left: 20px;">then</p> <p style="padding-left: 40px;">4.1 wait for REQUEST message from gateway "g_a"</p> <p style="padding-left: 40px;">4.2 directly send the data from the sensor node to base station through relay node.</p> <p style="padding-left: 20px;">else</p> <p style="padding-left: 40px;">4.3 s_a calculates the cost of the cluster head and join with the highest cost value cluster head.</p> <p style="padding-left: 20px;">end if</p> <p style="padding-left: 20px;">end if</p> <p>Step 5: - stop</p>
--

For calculating the cost of the cluster head node as follows

$$CH_{cost}(g_a, s_a) = \frac{E_{residual}(g_a)}{Dist(s_a, g_a) \times Dist(g_a, RN) \times Dist(RN, BS)}$$

Calculating the Area of the Sensing Field

$$\begin{aligned} \text{area of hexagon} &= \frac{3\sqrt{3}}{2} \times a^2 \\ \text{area of right angle triangle} &= \frac{ab}{2} \\ \text{area of equilateral triangle} &= \frac{\sqrt{3}}{4} \times a^2 \\ \text{radius of hexagon} &= \frac{\sqrt{3}}{2} \times a \\ \text{diameter of hexagon} &= \sqrt{3} a \end{aligned}$$

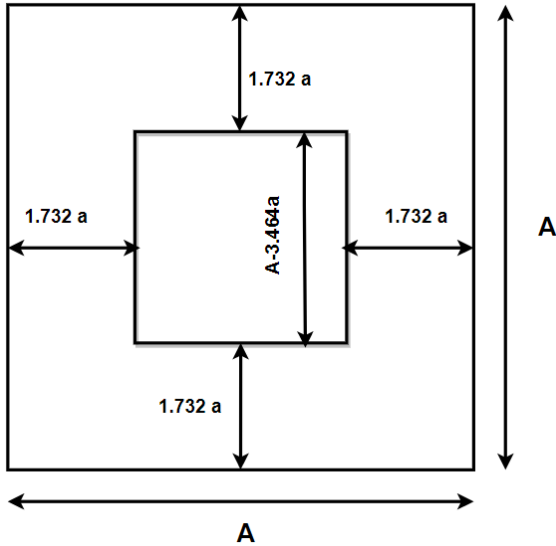

Fig. 7. Estimating the sensing area where nodes are deployed at boundary

$$\begin{aligned} \text{area of outer square} &= A^2 \\ \text{inner square area} &= (A - 2\sqrt{3}a)(A - 2\sqrt{3}a) \\ &= A^2 - A2\sqrt{3}a - A2\sqrt{3}a + (4 \times 3 \times a^2) \\ &= A^2 - 4\sqrt{3}aA + 12a^2 \\ \text{Sensing area} &= \text{Outer square} - \text{Inner square} \\ &= A^2 - (A^2 - 4\sqrt{3}aA + 12a^2) \\ &= A^2 - A^2 + 4\sqrt{3}aA + 12a^2 \\ &= 4\sqrt{3}aA - 12a^2 \end{aligned}$$

The above equation results

$$\begin{aligned} \text{Sensing area} &= 4\sqrt{3}aA - 12a^2 \\ &= a(4\sqrt{3}A - 12a) \end{aligned}$$

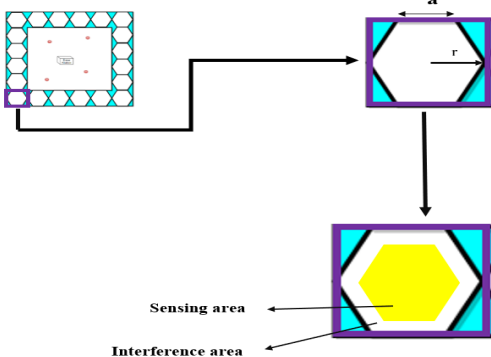

Fig. 8. Estimation of a coverage area of a node in WSN

$$\begin{aligned} \text{area} &= \text{area of hexagon} \\ &\quad + 4(\text{area of right angle triangle}) \\ &= \frac{3\sqrt{3}}{2} \times a^2 + 4\left(\frac{ab}{2}\right) \end{aligned}$$

5. Result Analysis

All the experiments and simulations have performed in MATLAB Simulink tool. The sensors are placed in the boundary of sensor field. The communication area has considered in a hexagonal shape of r distance from the edge and the radius of the sensor node is also same. All sensors are not worked at same time for energy conservation, sensor node work only if any object may present in its sensing object and this mechanism works on duty scheduling process. The node will send the notification to the mobile user and to the base station for the gadget activation for diverting the animal from the field. It is an energy effective technique uses limited power supply. The storage of data is limited due to not storing all the activities of a complete day. It will store the data only if any presence of object has detected by any sensor. Suppose if any node is failed at boundary then next two neighboring nodes can become the responsible nodes to cover the area of the failed node.

Table 4. Estimation of required no. of sensor nodes-based w.r.to field area

Field Area	a=2	a=4	a=6	a=8	a=10
10	6.53	6.14	6.14	-15.43	-36.6
50	46.53	86.14	86.14	144.55	163.39
100	96.53	186.14	186.14	344.54	413.39
200	196.53	396.14	386.14	744.51	913.39
300	296.54	586.14	586.14	1144.48	1413.39
400	396.54	786.14	786.14	1544.45	1913.39
500	496.55	986.14	986.14	1944.42	2413.39
600	596.55	1186.14	1186.14	2344.39	2913.39
700	696.55	1386.14	1386.14	2744.37	3413.39
800	796.55	1586.14	1586.14	3144.34	3913.39
900	896.56	1786.14	2680.51	3544.37	4413.39
1000	996.56	1986.14	2981.81	3944.28	4913.39

Table 5. Throughput, PDR and Network Lifetime of EEC-HC

No. of Nodes	Throughput-bits/sec	PDR (%)	Av. Energy Consumed by Node (%)
100	2.75*10 ⁵	99.37	86.57
200	5.85*10 ⁵	99.66	89.32
400	11*10 ⁵	98.88	91.79

The weak zone is another problem which identified after deployment of WSN. After placing the sensor nodes in sensor field, consider sensors s1 and s2 as shown in figure 10, weak zone or free space has identified. From weak zone or non-sensing area, a intrusion may very easily enter in agriculture field. To overcome this problem, estimation and deployment of optimum number of sensor nodes between s1 and s2 is highly essential. The results shown that, if communication radius may increase, the sensing area of the agriculture field may increase using optimum number of sensor nodes. To provide n-connectivity and n-coverage, placing the sensors are deployed of r distance. Hence there is no weak zone or non-sensing area has achieved using proposed mechanism.



Fig. 9. Optimum Sensor node s3 estimation and deployment between s1 and s2 to cover the weak zone area

6. Conclusion

The EECF-HC mechanism has identified the required optimum number of sensor nodes to eliminate the weak zones in sensor field. The nodes have identified the strong

communication links and achieved quality data transmission in WSN. The energy efficiency has achieved to higher level which resulted better network lifetime. As a future work, the weak zone between relay nodes has to be estimated to achieve higher throughput and packet delivery ratio using WSN.

This is an Open Access article distributed under the terms of the Creative Commons Attribution License



References

- Ojha, T., Misra, S., & Raghuwanshi, N. S. (2015). Wireless sensor networks for agriculture: The state-of-the-art in practice and future challenges. *Computers and Electronics in Agriculture*, 118, 66-84.
- Keshtgari, M., & Deljoo, A. (2012). A wireless sensor network solution for precision agriculture based on zigbee technology. *Wireless Sensor Network*, 4(1), 25
- Ojha, T., Misra, S., & Raghuwanshi, N. S. (2017). Sensing-cloud: Leveraging the benefits for agricultural applications. *Computers and Electronics in Agriculture*, 135, 96-107.
- Bapat, V., Kale, P., Shinde, V., Deshpande, N., & Shaligram, A. (2017). WSN application for crop protection to divert animal intrusions in the agricultural land. *Computers and Electronics in Agriculture*, 133, 88-96.
- Gasch, C. K., Brown, D. J., Brooks, E. S., Yourek, M., Poggio, M., Cobos, D. R., & Campbell, C. S. (2017). A pragmatic, automated approach for retroactive calibration of soil moisture sensors using a two-step, soil-specific correction. *Computers and Electronics in Agriculture*, 137, 29-40.
- Jain, R., Kulkarni, S., Shaikh, A., & Sood, A. Automatic Irrigation System for Agriculture Field Using Wireless Sensor Network (WSN), 2016
- Gawali, Y. G., & Chaudhari, D. S. (2016). Wireless Sensor Network based Monitoring for Agricultural System. *International Journal of Science, Engineering and Technology Research (IJSETR)*, 5(8).
- Amici, A., Serrani, F., Rossi, C. M., & Primi, R. (2012). Increase in crop damage caused by wild boar (*Sus scrofa* L.): the "refuge effect". *Agronomy for sustainable development*, 32(3), 683-692.
- Awasthi, B., & Singh, N. B. (2015). Status of human-wildlife conflict and assessment of crop damage by wild animals in Gaurishankar conservation area, Nepal. *Journal of Institute of Science and Technology*, 20(1), 107-111.
- Andavarapu, N., & Vatsavayi, V. K. (2017). Wild-Animal Recognition in Agriculture Farms Using W-COHO for Agro-Security. *International Journal of Computational Intelligence Research*, 13(9), 2247-2257.
- Sawant, S., Durbha, S. S., & Jagarlapudi, A. (2017). Interoperable agro-meteorological observation and analysis platform for precision agriculture: A case study in citrus crop water requirement estimation. *Computers and Electronics in Agriculture*, 138, 175-187.
- K. Anil Kumar, "IMCC protocol in heterogeneous wireless sensor network for high quality data transmission in military applications," In: 1st IEEE International Conference on Parallel, Distributed and Grid Computing, pp. 339- 343, 2010.
- Kakelli Anil Kumar, Addepalli V. N. Krishna, K. Shahu Chatrapati, "Interference Minimization Protocol in Heterogeneous Wireless Sensor Networks for Military Applications", Springer, vol 51, pp 479-487, 2016.
- Kakelli Anil Kumar, Addepalli V. N. Krishna, K. Shahu Chatrapati, "Congestion Control in Heterogeneous Wireless Sensor Networks for High-Quality Data Transmission", Springer, vol 439, pp 429-437, 2016.
- Kakelli Anil Kumar, Addepalli V. N. Krishna, K. Shahu Chatrapati, "Interference Minimization Protocol in Heterogeneous Wireless Sensor Network for High Quality Data Transmission", *International Journal of Applied Engineering Research*, vol. 10 No.81, 2015.
- Kakelli Anil Kumar, Addepalli V. N. Krishna, K. Shahu Chatrapati, "New Secure Routing Protocol with Elliptic Curve Cryptography for Military Heterogeneous Wireless Sensor Networks" *Journal of Information and Optimization Sciences (JIOS)*, vol 38, Issue 2, pp 341-365, 2017.

List of Symbols and Abbreviations

CH – Cluster Head
 R_s – Range of sensor node or Sensing Range
 R_c – Communication Range or Range of communication
 $E_{residual}$ – Residual energy of node (remaining or unused energy of a node)
 R_{cCH} – Communication range of Cluster Head node
 BS – Base Station
 D_{max} – Maximum distance covered by the Gateway or Cluster Head node
 CH_{cost} – Cluster Head Cost
 RN – Relay Node
 d – distance between two sensor nodes
 r – radius of sensor node